



USER'S GUIDE

soundshield™ BT



WHAT'S INSIDE



**Monaural
Headset**

OR



**Binaural
Headset**

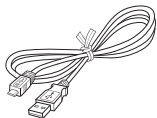

USB Charging Cable



Headset Hanger



SSBT Dongle

OPTIONAL ACCESSORIES

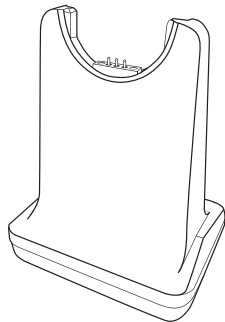

Charging Stand

HOW TO WEAR

To detach the microphone boom arm from the headband, gently push the microphone speaker from inside the ear cushion. This will pop the microphone boom away from the headband.

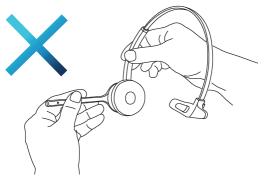
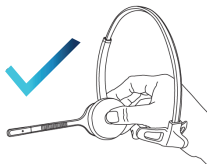

Do not pull on the microphone boom to remove it from the headband.

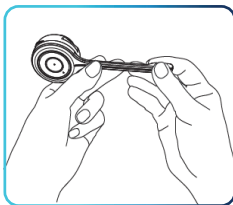

Positioning the microphone gently bend the boom and position it to suit the curve of your face.

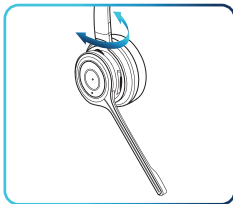

Holding the headset, rotate the headband to bring the boom close to your cheek.

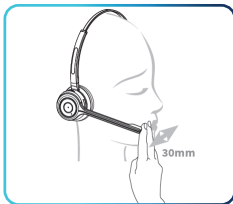

The ideal placement for the microphone is at the corner of your mouth, an inch from your face.

HEADSET CONTROLS

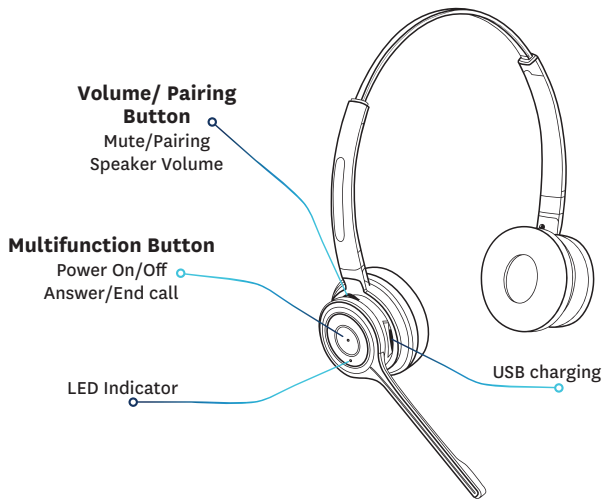

- If the headset has been out of use for some time, it may take up to 2 hours to fully charge.
- Normal charging time is 2-3 hours.
- Low battery is indicated by the flashing red LED on the headset.

DONGLE CONNECTION

PAIRING

- Plug the dongle into a USB socket on your device.
- Press and hold the dongle *LED button* for more than 3 seconds until the dongle enters pairing mode and the led indicator starts blinking.
- Press and hold the Multifunction button on your headset to enter pairing mode.
- When both devices are in pairing mode, the connection will be established automatically and the headset will announce the successful connection through a voice prompt.

The pairing mode is active for 1 minute and 20 seconds. After that, the dongle will enter standby mode.

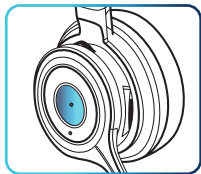
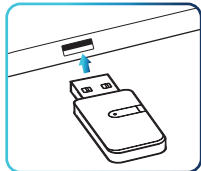
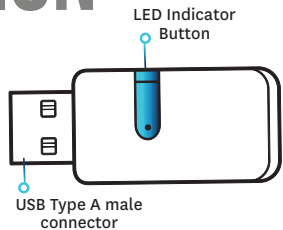

CONNECT PHONE

PAIRING

- Turn on Bluetooth on your phone.
- Place the headset on your head while it is switched off.
- Press and hold the multifunction button for 7 seconds until the headset beeps and the LED indicator starts flashing rapidly.
- Search for Bluetooth devices on your phone and connect to >>SSBT<<.
- Blue LED is On and 'Pairing done, Connected' is heard in the speaker when pairing is completed.

To unpair hold volume button down for 2 seconds to unpair.

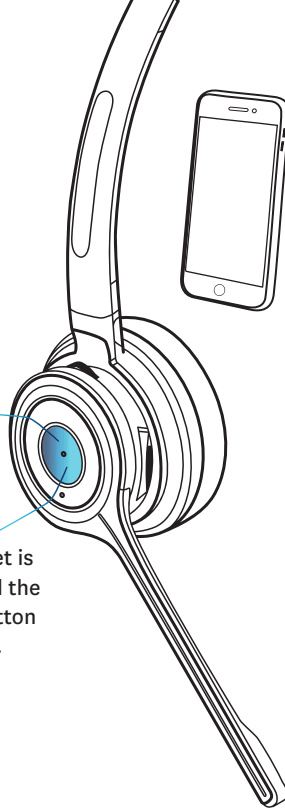

TURN ON
Hold the multifunction button for 2 seconds.

TURN OFF
While the headset is on press and hold the multifunction button for 3 seconds.

CALLS

ANSWER > Press the multifunction button briefly.

REJECT > Press the multifunction button for 1 sec while incoming call, 'Call rejected' is heard in speaker.

MAKE > Dial the number on the mobile phone and press the multifunction button briefly.

END > Press the multifunction button briefly or end the call on the mobile phone.

RE-DIALING > Press the multifunction button briefly twice until you can hear 'Re-Dialing' from speaker.

To mute/unmute press the volume button.



MUSIC CONTROLS

SKIP BACK > press and hold the volume minus (-) button.

SKIP A SONG > press and hold the volume plus (+) button.

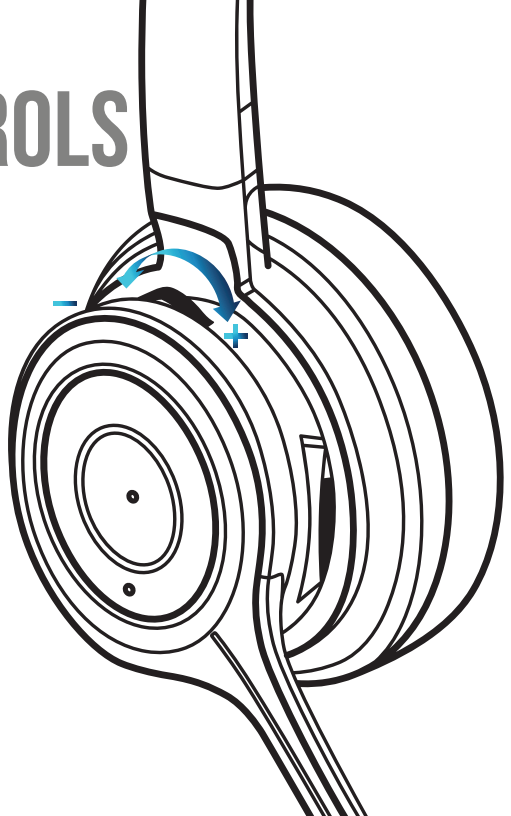

ATTACHING THE HEADBAND

To attach the microphone boom arm to the headband, align the triangle shape on the microphone boom arm with the triangle shape on the headband and push to click into place. The microphone boom arm will then rotate to your required position.

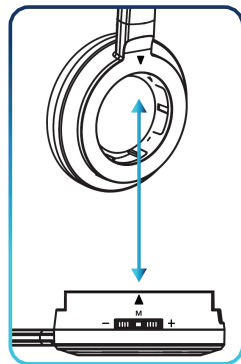
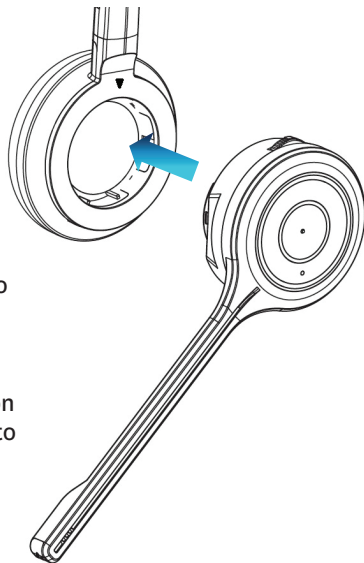

KEY TABLE

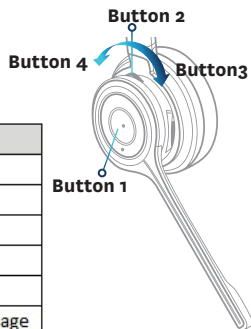

Button	Action	Condition	Fucntion
1	Short Press	Incoming Call	Accept Call
		On Talk Mode	End Call
	Long Press	Powered On	Power Off
		Power Off	Power On
		Incoming Call	Call Reject
	Double Press	Not Sync to BT Host	Change Voice Prompt's Language English->Spanish->French
Sync to BT Host		Redial(Smartphone Only)	
2	Short Press	On Talk Mode	Mute On/Off
		Music Listen	Pause On/Off
	Long Press	No Condition	Pairing Mode
3	Short Press	On Talk Mode	Volume Up
		Music Listen	Volume Up
	Long Press	Music Listen	▶▶ FF(SmartPhone Only)
4	Short Press	On Talk Mode	Volume Down
		Music Listen	Volume Down
	Long Press	Music Listen	◀◀ BackWard(SmartPhone Only)

PROBLEMS CONNECTING THE HEADSET

- Check that the headset is charged, turned on and within 10 meters of the phone/dongle.
- Check that Bluetooth is switched on your phone.
- Check that the headset is listed as a headset device in your phone and also connected. You may need to re-connect to the headset.
- Try removing the headset from the phone, then pair and connect again.

FCC INFORMATION

This device complies with part 15 of the FCC Rules. Operation is subject to the following two conditions:

1. This device may not cause harmful interference, and 2. This device must accept any interference received, including interference that may cause undesired operation. This equipment has been tested and found to comply with the limits for a CLASS B digital device, pursuant to Part 15 of the FCC Rules. These limits are designed to provide reasonable protection against harmful interference when the equipment is operated in a commercial environment. This equipment generates, uses, and can radiate radio frequency energy and, if not installed and used in accordance with the instructions, may cause harmful interference to radio communications. However, there is no guarantee that interference will not occur in a particular installation. If this equipment does cause harmful interference, the user is encouraged to try to correct the interference by consulting with a dealer or an experienced technician for technical assistance. Any changes or modifications to the equipment not expressly approved by the party responsible for compliance could void user's authority to operate the equipment.

WARNING & SAFETY INFORMATION

The antenna(s) used for this device must be installed to provide a separation distance of at least 20cm from all persons and must not be co-located or operating in conjunction with any other antenna or transmitter.



soundshield™ BT

© 2020 Polaris Communications Pty Ltd
For warranty policies and terms and conditions please visit
www.polaris.com.au/terms-conditions/



Polaris Head Office
393 Flemington Road
North Melbourne VIC 3051 AUS
PH: 1800 626 505
FAX: 1800 079 036
sales@polaris.com.au